

ELEVATE MONITOR ARM⁵⁵

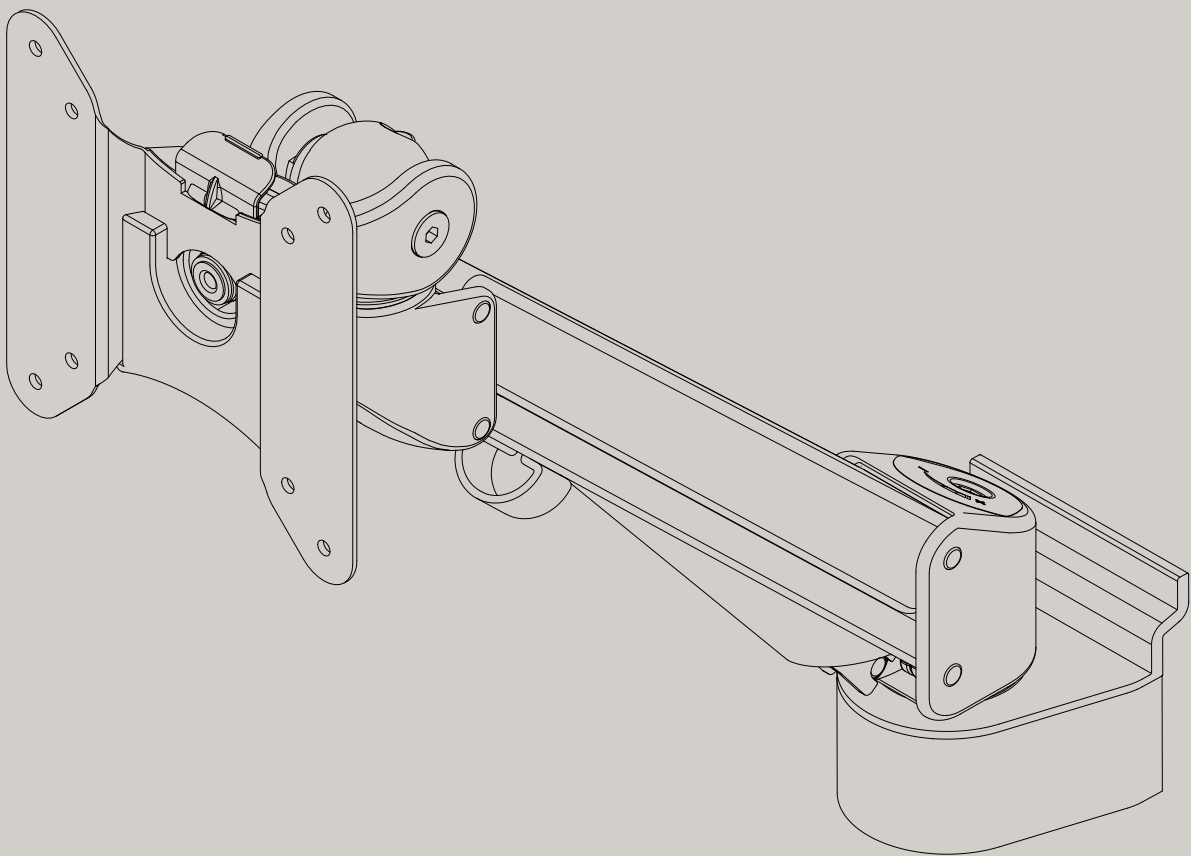

Dimensions

See user manual for assembly instructions.

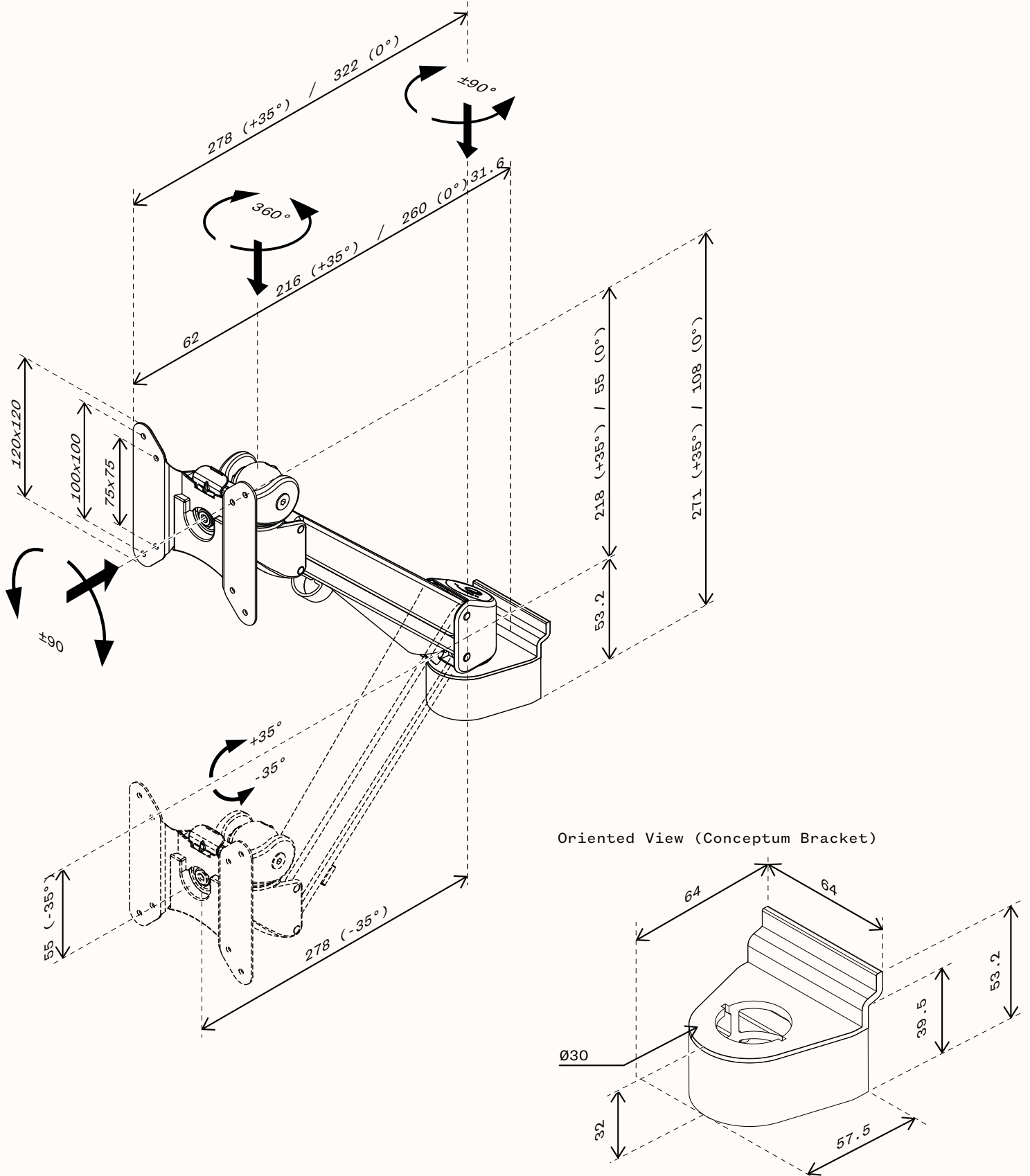

ELEVATE MONITOR ARM⁵⁵

3-8 KG, GAS SPRING, RAIL MOUNTED, BLACK/WHITE/SILVER

ART. NO

4385505509	BLACK	RAL9005
4385505501	WHITE	RAL9016
4385505502	SILVER	RAL9006

Technical data

MATERIAL	ALUMINIUM AND STEEL
FINISH	BLACK/WHITE-MATTE, SILVER-METALLIC
MAXIMUM ARM LENGTH	300mm
WEIGHT SPAN	3-8-14kg*
VESA	75/100mm
TABLE THICKNESS	8-30mm

* Weight span is calculated based on monitor with Centre of Mass shorter than 30mm from VESA interface. For curved or bigger screens, the weight span might differ.