

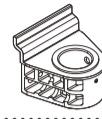

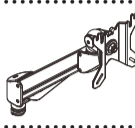









Elevate Monitor Arm⁵⁶

PARTS AND TOOLS

(A1)	x1 PCE	
(A2)	x1 PCE	
(B1)	x2 PCS	
(B2)	x2 PCS	
(C1)	x2 PCS M6x12	
(C2)	x2 PCS M6x15	
(D1)	x4 PCS M4x10	
(D2)	x4 PCS M4x15	
(E)	x4 PCS	
(F)	x1 PCE	
(G)	x1 PCE 5mm	
(H)	x1 PCE 2mm	
(I)	x1 PCE NOT INCLUDED	

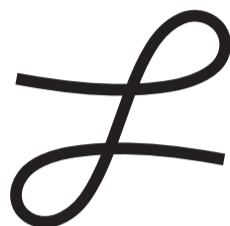

FORMINGFUNCTION.SE

FORMING  FUNCTION

USER MANUAL

Before installation: Please follow the instructions. If there is a step you don't understand, please contact your sales representative. Note that all measurements and conditions must be verified on site. Neither Forming Function nor any of its distributors can be held liable for product malfunction or other defects caused by improper installation.



STEP 1

Hook the bracket (A1) into the track of your compatible aluminium profile (See STEP 2 for compatibility).

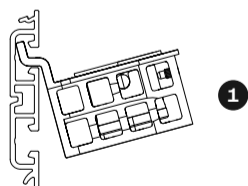

Combine bracket with monitor arm (A2) and secure its position with Allen key (F).

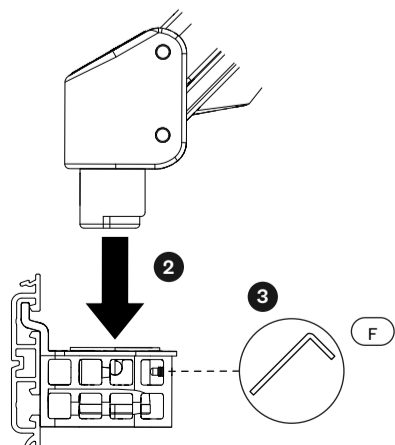

STEP 2

Identify the correct nuts and screws using the figures. Then, fixate the monitor arms to the desired position on the aluminum profile.

UNIFORM RAIL

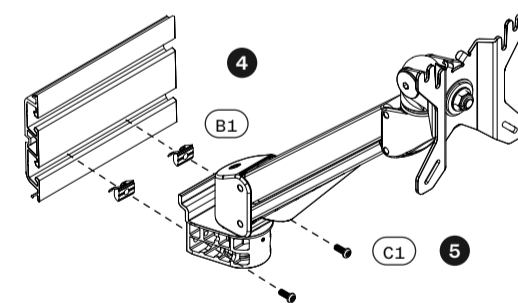
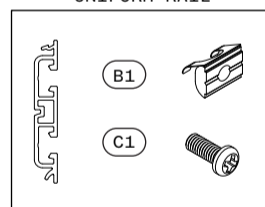

AXESSLINE TOOLBAR

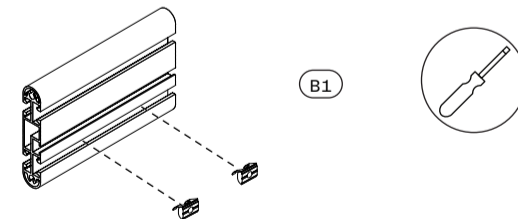
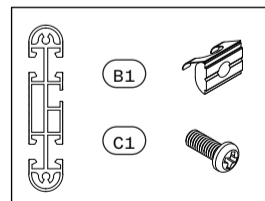

OTHER POSSIBLE ASSEMBLIES

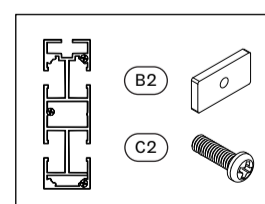

REQUIRED NUT IS NOT INCLUDED. PLEASE CONTACT FORMING FUNCTION

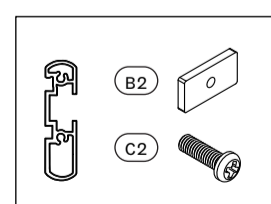

Insert the nut with the blocky side towards yourself and the rounded side towards the aluminum profile for best grip (as illustrated to the left). Once inserted, make sure to center and align the components before fastening the screws (as illustrated to the right).

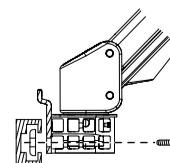

STEP 2A

Check that the VESA bracket fits flat against the back of your monitor.
If spacers (E) are needed, please proceed to STEP 2B.

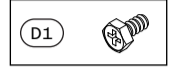
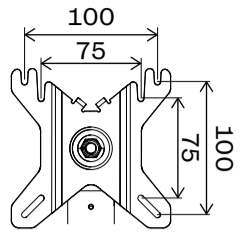

1 Mount both upper screws half-way into the monitor.

2 Slide the upper screws onto the tracks of the VESA bracket.

3 Fasten all four screws

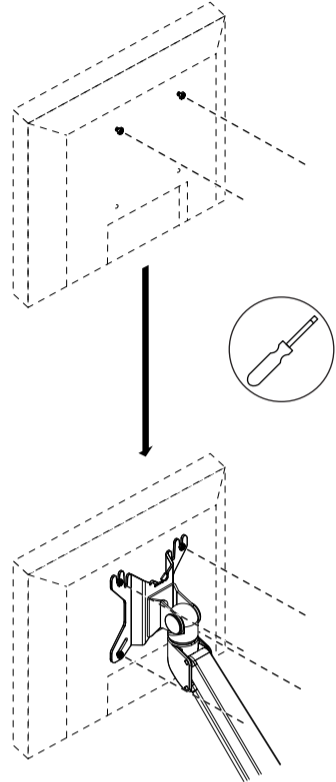

STEP 2B

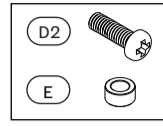

1 Attach all spacers (E) with the screws (D) to the VESA bracket

2 Hold the monitor and fasten all four screws.

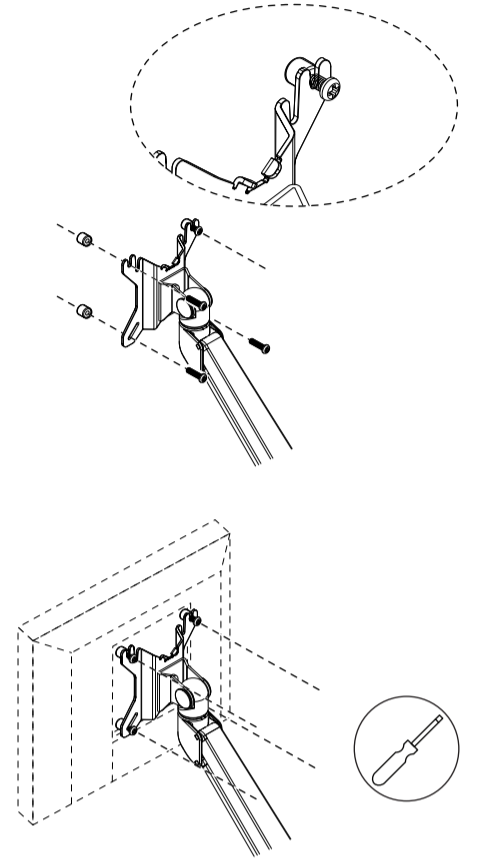

STEP 3

Attach the cover on the bottom bracket.

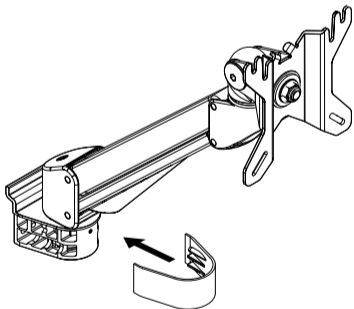

STEP 4

Detach the small cable collector and route the cables through. Once satisfied, re-attach the collector back into place.

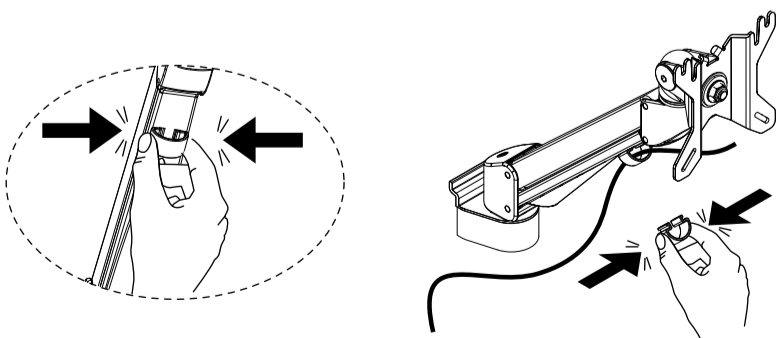

TENSION ADJUSTMENTS

CAUTION:
Support and hold on to the arm while adjusting the tension.

ADJUSTMENT:
Use the Allen key provided to adjust the tension to correspond to the weight of the desired monitor. Turn the Allen key counter-clockwise to adjust for heavier monitors; clockwise for lighter monitors. Once the adjustment is done, the monitor should be experienced as weightless and the monitor should remain in any position without dropping nor rising.

RECOMMENDATIONS:

- 8-14 kg (17.6-30.8 lbs).
- The products loading capacities are based on monitors' center of gravity less than 3 cm from the end of the VESA interface.
- Loading capacity could be reduced if the monitor size is greater than 26 inches or if the thickness exceeds 5.5 cm.
- All product specifications in catalogues are subject to change without notice.

